

**Basic knowledge
Fabric tensioning**

The front side of all of the profiles has a frameless design, meaning that the motif can run right up to the outer edge of the profile. The fabric is clamped and unclamped at the side.

Fabric allowance and fabric cutting with frameless flat cover EPS 1-022 and EPS 1-023

Add **63 mm fabric allowance** to the outer dimension of the assembled housing all around.

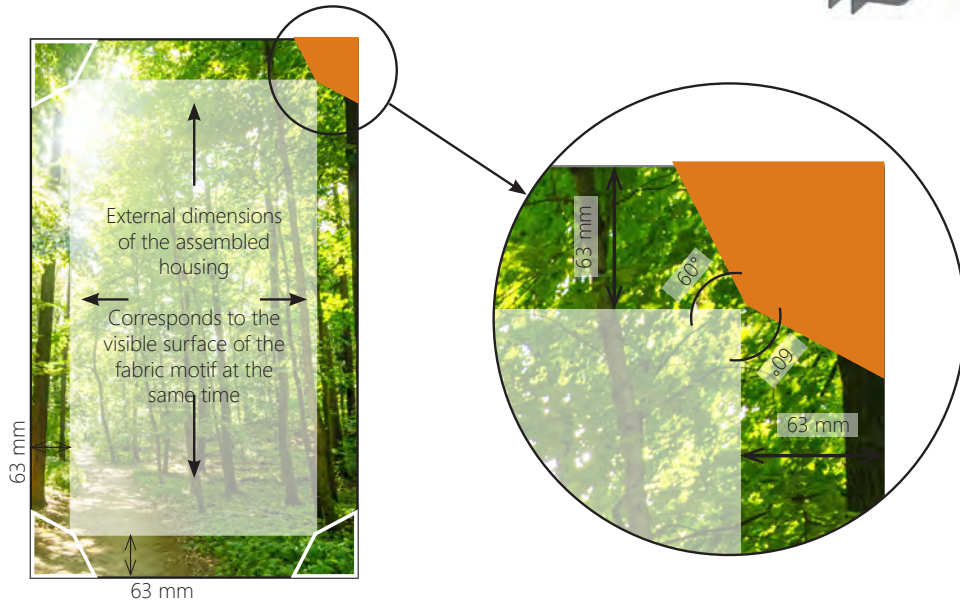
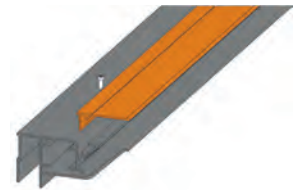

Add 63 mm to the external dimensions of the housing.

Remove the orange area of the fabric.

Fabric allowance and fabric cutting with broad cover profile EPS 1-300 and EPS 1-301

Add **59 mm fabric allowance** to the outer dimension of the assembled housing all around.

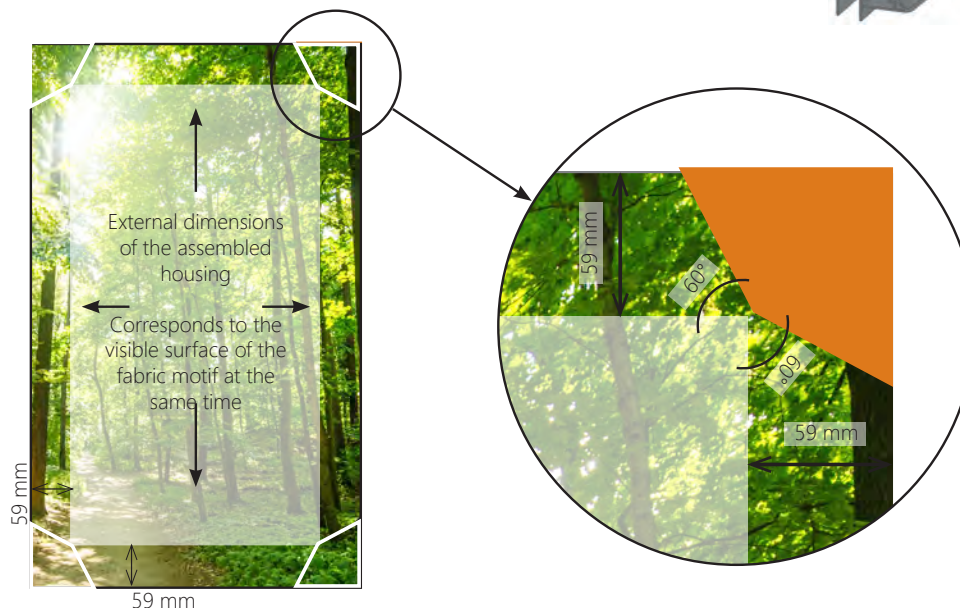
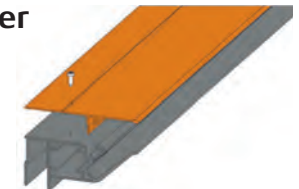

Add 59 mm to the external dimensions of the housing.

Remove the orange area of the fabric.

Notes on the mass per unit area of the fabric

The mass per unit area of a PVC coated polyester fabric should be at least 550 grams/square metre. In the event of a lower mass per unit area, the edge may need to be reinforced because the flexholder does not grip.

For formats with a length > 4 m, we recommend cutting the precise fabric allowance on site when in a half-tensioned state and then clamping the flex holders into place since temperature differences may influence the size of the fabric. If the fabric is still too long, release the flex holders with the flex holder pliers and cut the fabric down again.

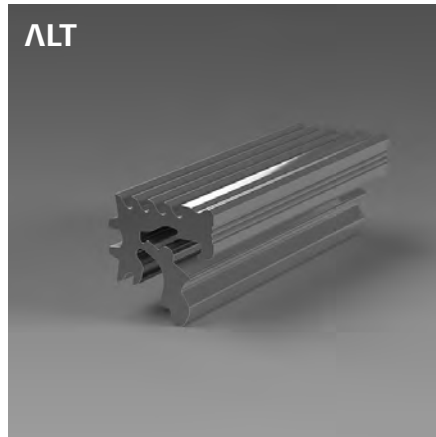

Old version 50 mm:
EPS 1-072
EPS 1-074
EPS 1-077

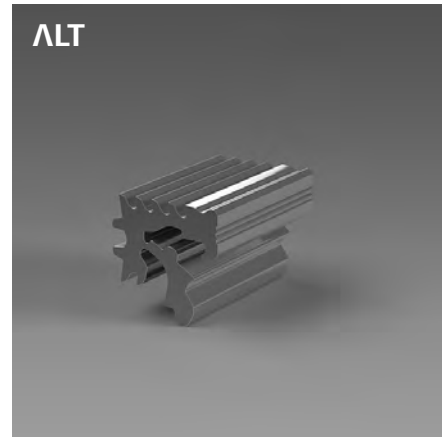

Old version 25 mm:
EPS 1-092
EPS 1-094
EPS 1-097

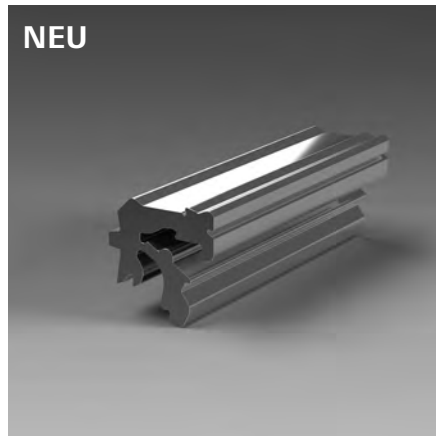

New version 50 mm:
EPS 1-072-001
EPS 1-074-001
EPS 1-077-001

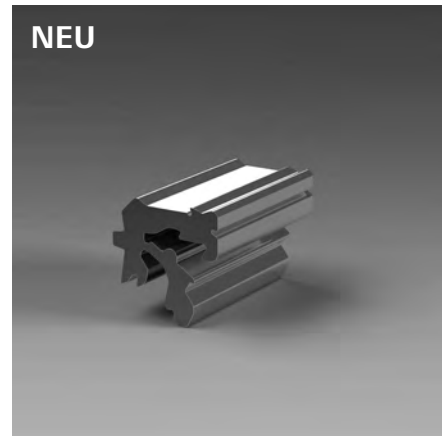

New version 25 mm:
EPS 1-092-001
EPS 1-094-001
EPS 1-097-001

Compared to the old ones, the new flex holders have no ribbing on the top. This difference is purely visual and has no influence on the known technical functions.

If you have any questions, please do not hesitate to contact us.

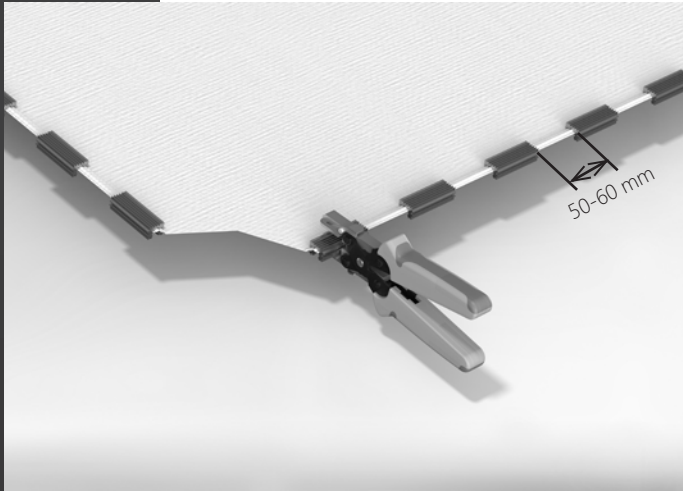

Starting from the corner of the fabric, the flex holders are applied with gaps of 50 - 60 mm between them. In order to achieve optimum tension: the larger the fabric area, the smaller the gaps between the holders.

Using the flex holder pliers, compress the flex holder on the fabric until it engages perceptibly. Important: The smooth side of the flex holder must face the visible area of the fabric when clamping.

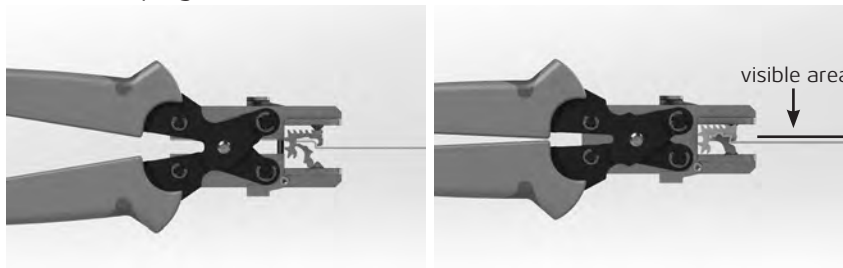

To open the flex holder, the clamping lug of the flex holder must be bent open in the opposite direction.

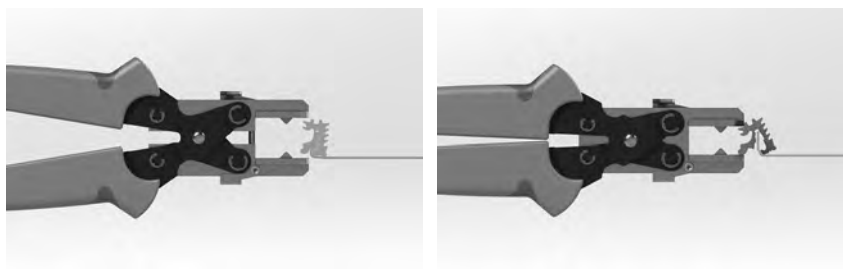

In order to be able to clamp the fabric correctly, the flex holder is folded once in the direction of the visible area and then inserted in the clamping channel of the profile!

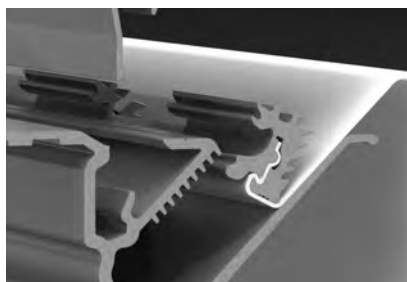

When installing PVC coated fabric a minimum ambient temperature of 8° Celsius should be ensured. In the event of lower temperatures, the fabric may buckle or be damaged in other ways. For small and medium formats, do not tension the fabric too firmly.

For formats with a length > 4 m, we recommend cutting the precise fabric allowance on site when in a half-tensioned state and then clamping the flex holders into place since temperature differences may influence the size of the fabric. If the fabric is still too long, release the flex holders with the flex holder pliers and cut the fabric down again.

Do not equip the frames with fabric when they are lying down since the fabric sags as a result of its own weight and you will thus have difficulties engaging the flex holders in the LUMI profile. In order to ensure optimum tensioning, always ensure the frame is upright.



Insert the first three flex holders on the sides and the top edge and engage into the first or second tooth of the profile. When inserting each flex holder pull the fabric firmly away from the starting point in order to prevent wrinkles.



To finish the top row, insert the first flex holder on the opposite side and engage.



Finish inserting the side flex holders and engage into the first or second tooth.

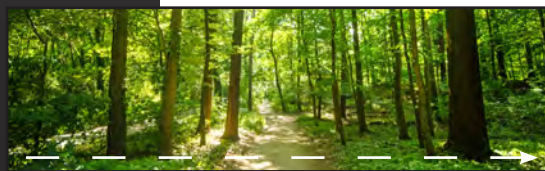

Insert the bottom flex holders and engage into the first or second tooth. Only when this step is completed may you start actually tensioning using tensioning tools.



Use a tensioning fastener to push the flex holders on the left and right deeper into the profile and thus to tension the flex.

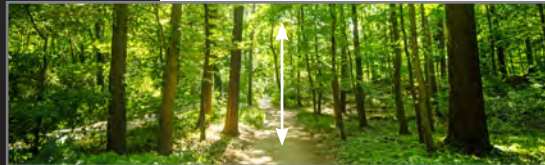

Then push the flex holders along the top and bottom edges deeper into the profile. If necessary, go round all flex holders again and tension further.

Tensioning the fabric

Minimum tensioning depth of the flex holder

In order to ensure that the fabric is provided with optimum and secure tension when you have completed tensioning, the flex holders should be engaged in the middle section of the toothing of the tensioning profile.

The fabric can be tensioned in two ways:

1. With the tensioning tool

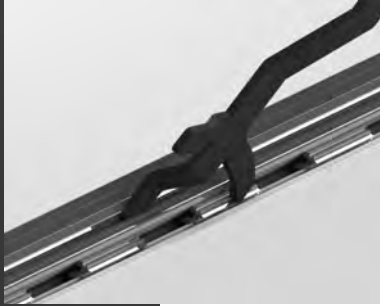

Insert the nipple at the centre tip of the tensioning tool into the profile groove above the tensioning channel. Press down the left or right tip of the tensioning tool to engage the flex holder in the teeth of the tensioning channel and tension the fabric. Then seal the tensioning channel with the cover profile and use screws to prevent it from springing off unintentionally.

Important: The tensioning tool cannot be used with LUMI GRIP profiles.



2. Tensioning with flex holder fastener and rubber hammer

In order to securely tension the fabric, apply the flex holder fastener like a chisel to the flex holder and use the mallet to drive it deeper into the profile. For small and medium formats, do not tension the fabric too firmly.

Then seal the tensioning channel with the cover profile and use screws to prevent it from springing off unintentionally.



Releasing the fabric

The cover profile can be removed from the profile using the profile remover. To release the flex holder, use a wide screwdriver to lever the flex holder from the tensioning profile, thus disengaging it and allowing it to be removed from the tensioning profile along with the fabric.

IMPORTANT NOTE:

When using black or dark fabrics, as well as those where the entire surface has dark print or lettering, the heat generated as a result of direct sunlight may cause wrinkles to appear.

EPS

SYSTEMS

EPS GmbH
Hauptstr. 42
57555 Mundersbach/Germany
Fon +49 (0) 271.338829-00
info@eps-systems.de
www.eps-systems.de